

This Exam is an open book

Answer all questions.

Assume any missing data

Question one (50%):

The figure shows a gear train consisting of helical gears, bevel gears, and a worm and worm gear. The helical pinion rotates at 1520 RPM in the direction shown.

1. Find the speed and direction of rotation of the worm gear.
2. Determine the axial and radial loads on worm gear axis "A" when the input power to the helical pinion is 1 kW. (The coefficient of friction between worm and the worm gear may be taken 0.05).
3. What is the maximum power, which could be transmitted by this gear train at the same input speed? In case of the worm was made of steel with BHN 500 and the worm gear was made of phosphor bronze.
4. Calculate the forces on all bearings and select the type and the size of all bearings based on 1000 hr life of the gear box and the maximum power.
5. Draw a free hand sketch for the worm shaft construction?

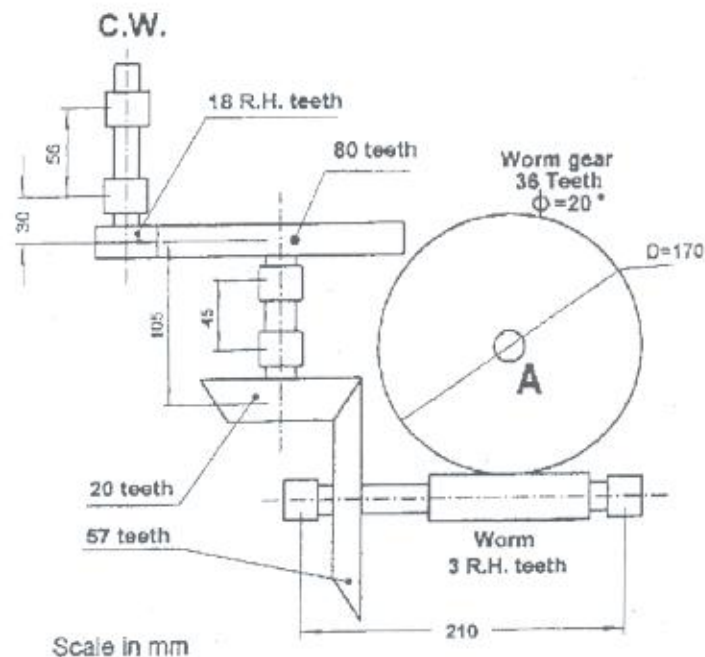

Question two (50%):

The figure shows the layout of a drum hoist driven by a 1160 PRM motor through a double reduction gearbox. The speed ratio of the first stage of reduction, using helical gears between the motor shaft (a) and the intermediate shaft (b), is 4:1. The second stage of reduction, using bevel gears between shaft (b) and drum shaft, has a ratio of 5:1. The drum is 400 mm in diameter, and the maximum cable load is 5kN.

The helical gears have 20° normal pressure angle, 30° helix angle, and 4 mm transverse module, the bevel gears have a pressure angle of 20° and a module of 6 mm.

Uniform condition of loading is assumed and precision gearing arrangement is required as well as high reliability and infinite life.

Pinions of both helical and bevel gears are to be cut from 0.4%C quenched and tempered steel, while gears are cut from good grade cast iron.

You are required to :

- 1) Suggest suitable hand for the helical gears, if the motor shaft rotates C.W. to raise the load.
- 2) Tabulate the values of the torque in N.m and the speed in RPM for shafts (a), (b), (c).
- 3) What horsepower of motor would you recommend.
- 4) Find the forces acting on both the bevel and helical gears.
- 5) Find the safe face width of the helical gear arrangement.
- 6) Find the diameter of shaft (b).
- 7) What are the loads that bearing (A) and (B) will carry. Select suitable bearing at (A) for a life of 10000 hrs and 99% reliability.
- 8) By neat sketch, show the fixation of bearings (A) & (B) on shaft (b).

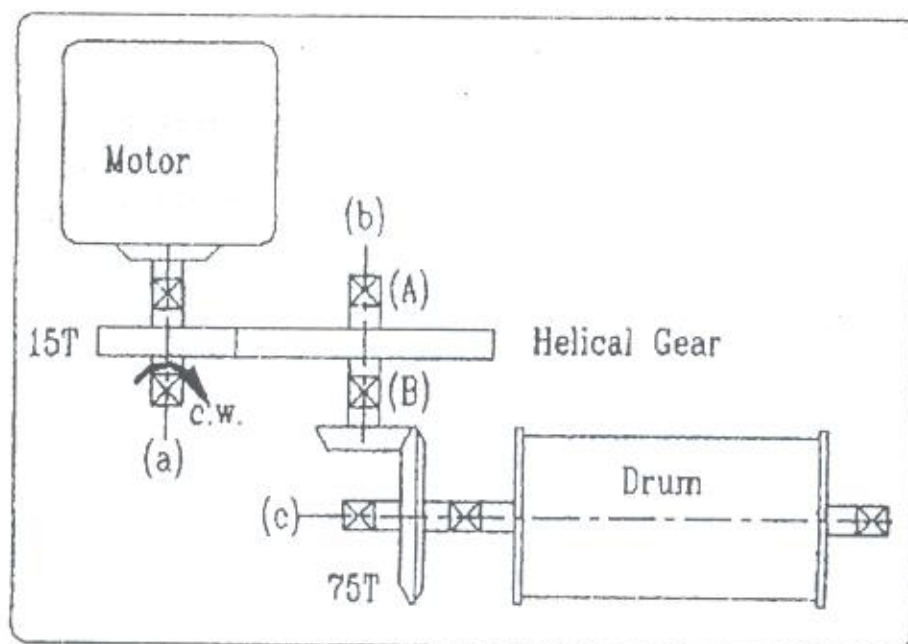

Question one:

- A) Describe the common operations on a drill?
- B) Calculate the rev/min at which a drill press should be set drill a 14 mm hole in a piece of machine steel, (CS 30 m).

Question two:

- A) Explain the common methods for turning tapers on a lathe?
- B) It has shown in Figure below a workpiece, outer diameter 25 mm, 60 mm length being machined to the three diameters longitudinal and facing turning in the drawing below. Write process sheet to turning a workpiece as shown in the Figure. The maximum depth of cut is 2 mm, spindle speed is 100 rev/min and feed rate is 0.3 mm per rev.

Question three:

- A) Explain the differences between conventional and climb milling?
- B) Estimate the machining time that will be required to finish a vertical flat surface of length 100 mm & depth 20 mm by an 8 teeth HSS end mill cutter of 32 mm diameter and 60 mm length in a milling machine. Cutting velocity = 30 m/mm and Feed = 0.12 mm/tooth.

Question four:

- A) Compare between compound and differential indexing?
- B) Calculate the indexing and change gears required for 57 divisions. The change gears supplied with the dividing head are as follows: 24, 24, 28, 32, 40, 44, 48, 56, 64, 72, 86, 100.

The available index plate hole circles are as follows:

Plate 1: 15, 16, 17, 18, 19, 20

Plate 2: 21, 23, 27, 29, 31, 33

Plate 3: 37, 39, 41, 43, 47, 49.

- C) Mention and explain the different types of grinding operations?

- D) Mention the factors which effect and guide line of the selection of grinding wheel?

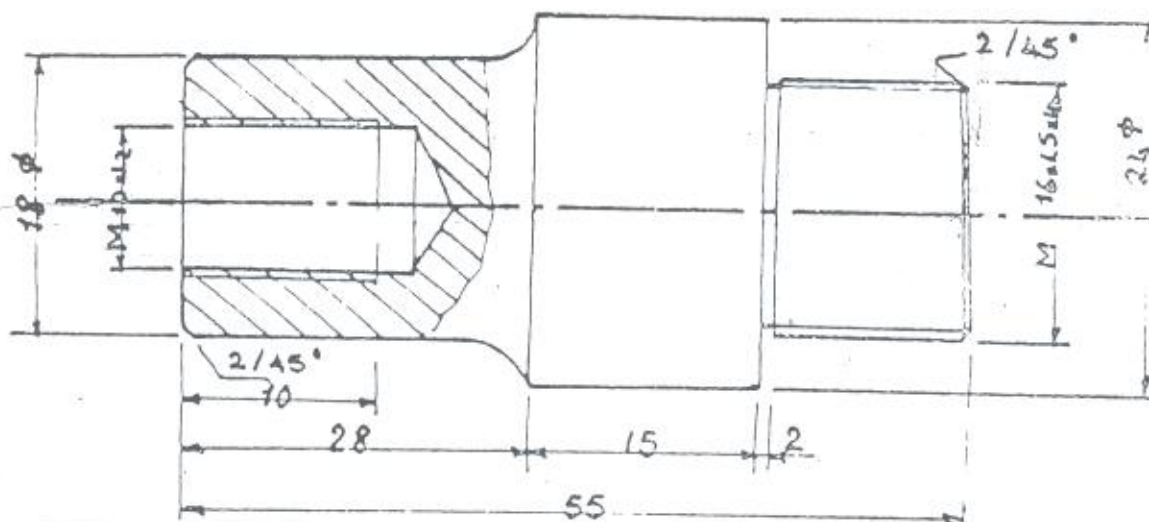

Answer the following questions:

Question 1: (Answer two points only)

- a- What is meant by the cut-off wavelength of an optical fiber? Determine the cut-off wavelength for a step index fiber to exhibit single mode operation, when the core refractive index and radius are 1.46 and 4.5 μm , respectively, with the relative index difference being 0.25%.
- b- What are the main requirements in fiber materials? Compare between the different types of fiber materials.
- c- Compare between the different dispersion mechanisms in an optical fiber link. Explain with the aid of sketches how solitons can be used to reduce dispersion.

Question 2: (Answer two points only)

- a- When a perform is drawn into a fiber, the principle of conservation of mass must be satisfied under steady state drawing conditions. This is represented by:

$$s = S \left(\frac{D}{d} \right)^2$$

where D and d are the perform and fiber diameters, and S and s are the perform feed and fiber drawing speeds, respectively. A typical drawing speed is 1.2 m/s for a 125 μm outer diameter fiber. What is the perform feed rate in cm/min for a 9 mm diameter perform?

- b- Assume that the input wavelengths of a 2 x 2 silicon MZI multiplexer are separated by 10 GHz (i.e., $\Delta\lambda = 0.08 \text{ nm}$ at 1550 nm). With $n_{\text{eff}} = 1.5$ in a silicon waveguide, show that the waveguide length difference must be given by:

$$\Delta L = \frac{c}{2n_{\text{eff}} \Delta\nu}$$

Calculate ΔL . Explain with the aid of sketches how can you build a 4 x 4 multiplexer from this 2 x 2 multiplexer.

- c- Consider an N node star network in which 0 dBm of optical power is coupled from any given transmitter into the star. Let the fiber loss be 0.3 dB. km. Assume the stations are located 2

km from the star, the receiver sensitivity is -38 dBm, each connector has a 1 dB loss, the excess loss in the star coupler is 3 dB, and the link margin is 3 dB.

- i. Determine the maximum number of stations N that can be incorporated on this network.
- ii. How many stations can be attached if the receiver sensitivity is -32 dBm?

Question 3: (Answer two points only)

- a- What is the difference between the electrical and optical bandwidths of the LED? Explain with the aid of sketches how they are related to each other. Consider an LED having a minority carrier lifetime of 5 ns. Find the 3-dB optical bandwidth and the 3-dB electrical bandwidth.
- b- Derive the lasing conditions of a laser diode. A GaAlAs laser diode has a 500 μm cavity length, which has an effective absorption coefficient of 10 cm^{-1} . For uncoated facets the reflectivities are 0.32 at each end. What is the optical gain at the lasing threshold? If one end of the laser is coated with a dielectric reflector so that its reflectivity is now 90%, what is the optical gain at the lasing threshold?
- c- Explain with the aid of sketches the lensing schemes for coupling improvement in optical communications. Find an expression for the coupling efficiency of a nonimaging microsphere.

Question 4: (Answer two points only)

- a. Explain with the aid of sketches with the aid of sketches a fiber connector scheme and a fiber splicing schemes. Prove that the common core area of a two axially misaligned step index fiber is given by:

$$A_{\text{comm}} = 2a^2 \arccos\left(\frac{d}{2a}\right) - d\left(a^2 - \frac{d^2}{4}\right)^{1/2}$$

Where d is the axial displacement. If $d=0.1a$, what is the coupling efficiency in decibels?

- b. Explain with the aid of sketches the idea of operation of the pin and the avalanche photodiodes. Explain also how you can use the Fourier transform to analyze the optical receiver operation.

- c. Find an expression for the probability of error in a digital optical receiver. What is meant by the quantum limit?

Question 5: (Answer two points only)

- a- What is meant by the rise time budget of a digital optical link? Explain the main items that affect the overall rise time of the optical link.
- b- Consider an optical link that consists of a LED with output power of -13 dB coupled into fiber flylead. A silicon PIN receiver with sensitivity of -42 dB. Two connectors at the ends; each has loss of 1 dB. The fiber attenuation is 3.5 dB/Km. The system margin is 6 dB. The system bit rate is 20 Mb/s. Find the length of the transmission path. Represent the link power budget graphically.
- c- Explain with the aid of sketches the subcarriers multiplexing process in the cable TV optical systems. How can you select the laser modulation index for multi input signals? What is the intermodulation distortion problem? Can this problem be solved? Why?

Question 6: (Answer two points only)

- a- Define the dynamic range of an optical Bus network. What is the significance of this parameter? From the loss point of view? Is it preferable to communicate with a Bus optical network or a Star network? Why?
- b- Show mathematically how you can build a Mach-Zhender multiplexer.
- c- Explain with the aid of sketches the basic idea of operation of the optical filter.

Question 7: (Answer two points only)

- a- Explain with the aid of sketches the idea of operation of tunable optical sources.
- b- Explain with the aid of sketches the idea of operation of tunable optical filters.
- c- Explain with the aid of sketches the operation principles of the optical amplifier.
- d- Explain with the aid of sketches the different types of noise in a digital optical system.

Best wishes.

استاذة هندسة الميكانيكا ٢٠١٠/٦/١٢



إمتحان نهاية الفصل الدراسي الثاني

٢٠١٠/٠٩ م

الفرقة الثالثة - المادة : تحكم آلي

تاريخ الإمتحان : ٢٠١٠/٦/١٣ م - الزمن : ٣ ساعات

جامعة طنطا

كلية الهندسة

قسم هندسة الإنتاج والتصميم الميكانيكي

1- DRAW EACH OF THE PHYSICAL SYSTEM AND BLOCK DIAGRAM FOR : HYDRAULIC CONTROLLER , ELECTRONIC DIFFERENTIAL AMPLIFIER and COMBINED MECHANICAL SYSTEM (Spring - Damper – Mass).

2- USE MASSON'S LAW TO FIND OUT THE OVER ALL TRANSFER FUNCTION OF THE CONTROL SYSTEM SHOWN.

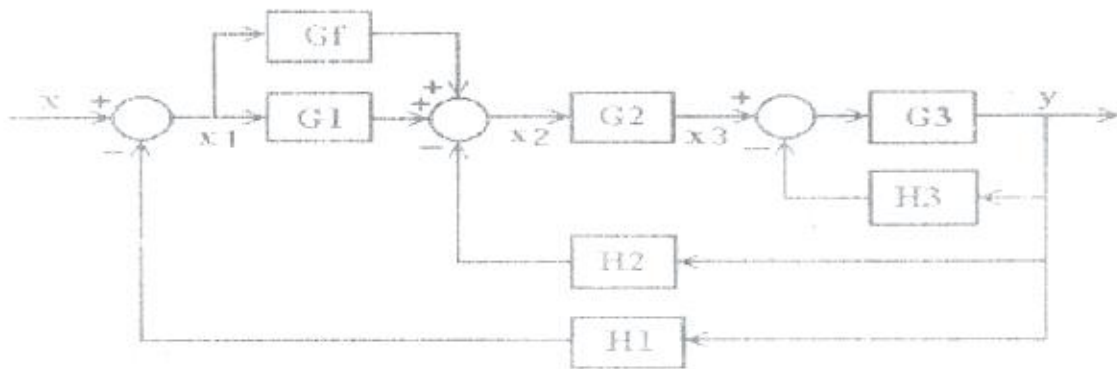

3- FIND OUT THE OVERALL TRANSFER FUNCTION OF THE CONTROL SYSTEM SHOWN USING THE GRAPHICAL METHOD.

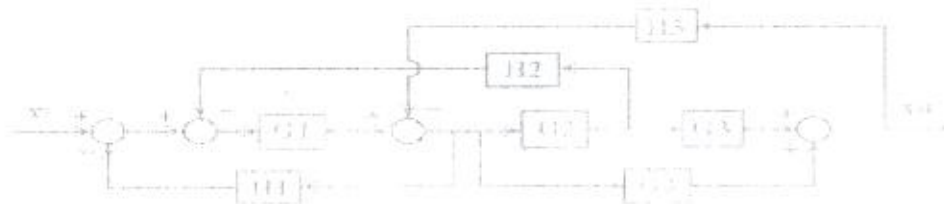

4- FIND OUT THE TIME RESPONSE OF THE CLOSED -LOOP CONTROL SYSTEM SHOWN, IF THE INPUT IS A UNITY STEP SIGNAL AND THE SYSTEM HAS ZERO INITIAL CONDITIONS.

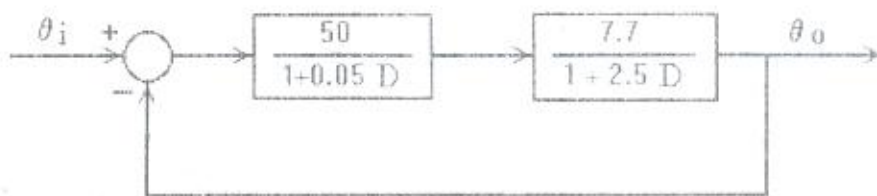

5- IF THE OVERALL TRANSFER FUNCTION OF A CLOSED-LOOP CONTROL SYSTEM IS IN THE FORM:

$$\frac{\Theta_o}{\Theta_i} = \frac{385}{0.125D^2 + 2.55D + 386} \text{ AND THE INPUT } \Theta_i \text{ IS A UNIT STEP SIGNAL, FIND OUT THE}$$

FOLLOWING:

- 1) RISE TIME (t_r).
- 2) PEAK TIME (t_p).
- 3) MAXIMUM PEAK (M_p).
- 4) STEADY STATE-ERROR
- 5) SETTING TIM (t_s) IF THE RESPONSE ALLOWANCE IS $\pm 5\%$

Final Exam

Solve all questions:

Question 1 : (25 marks)

- a) Define cold forming and hot forming and talk about the factors affecting the recrystallization temperature.
- b) The shown plane round part with a square hole is required to be produced in mass production from mild steel sheets of thickness 4 mm. The used steel has a shearing resistance of 450 MPa.
- Construct a suitable die-set to produce the part.
 - Calculate the required force according to your die-set selection.
 - Show with neat sketches the possible defects in the part and the methods to avoid these defects.
- c) Upon performing a deep drawing process fracture is observed. What could be the possible reasons for that?

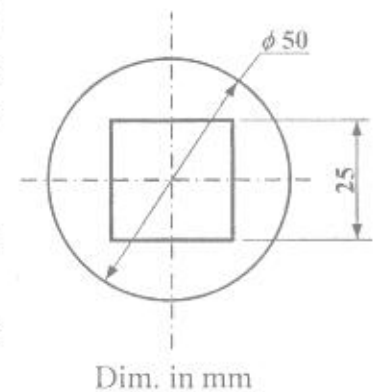

Question 2 : (25 marks)

- a) Define: bloom – billet – slab – plate – sheet – strip
- b) With the aid of sketches show the main types of rolling mills.
- c) The shown section of radius R is to be produced from a flat strip by contour rolling from one stage. The material has a modulus of elasticity of 200 GPa and a yield stress of 250 MPa.



- Derive an expression for the maximum elastic strain value in the section.
- If $R = 50$ cm and $\theta = 30^\circ$, what is the minimum distance between the two stations to prevent (تمنع) occurrence of wrinkles?
- How can we reduce the distance between the two stations without increasing the strain?

Question 3 : (25 marks)

- a) Compare of forward and backward extrusion in terms of:
methodology – advantages and disadvantages
- b) What is the ideal microstructure for a steel wire to have before its drawing process? Explain with the aid of a T-T-T curve how can we reach that microstructure.
- c) A tank cover made of steel sheet of thickness " t " takes the shape of a hemisphere of diameter " D " is to be produced by explosive forming.
- Derive an expression to calculate the required deformation energy.
 - If the cover has a 1 m diameter and final thickness of 2 mm and the steel alloy has a hardening law of $\bar{\sigma} = 650 \bar{\phi}^{0.22}$ (MPa). The amount of energy per unit explosive mass is $4 * 10^7$ J/kg and the overall efficiency is 0.4 . What is the explosive mass necessary for the process?

Question 4 : (25 marks)

- a) What are the advantages of the forging processes?
- b) Explain with the aid of sketches the difference between the following forging processes:
upsetting – edging – drawing down
- c) Show with drawings the production by forging of :
- bolt head.
 - Stepped shaft.
- d) Give two examples on how to control flow lines in forging.

مع تمنياتي بالتوفيق و النجاح

أجب علي خمسة من الأسئلة التالية:

- ١- بين الفرق بين القاعدة القانونية والقرار الإداري ، والفرق بين القاعدة القانونية والقاعدة الخلقية.
- ٢- يقوم العقد المدني علي أركان ثلاث رئيسية ، بين الأركان الثلاث مع الشرح بإيجاز لركن واحد منها.
- ٣- ماهي الشروط الواجب توافرها في المحل عند النص عليه في العقود المدنية ، ومتي يكون محل الإلتزام باطلا؟
- ٤- ماهي أنواع الأجر في المقولة ، وماهي الآثار المترتبة علي عقد المقولة؟
- ٥- وضح الفرق بين العقد الرضائي والعقد الشكلي ، والفرق بين العقد الفوري والعقد المستمر.
- ٦- وضح العناصر الرئيسية التي يتكون منها تقرير الخبرة الفنية ، وما هي أهم الشروط الواجب توافرها في المعاينة الفنية للخبير الفني؟